

Injection Pumps

WEBAC® IP 2K-F2 CE

- ▶ WEBAC® IP 2K-F2 is a compressed air-operated 2C double piston pump specially designed for applying PU injection resins with a shorter pot life and low viscosity.

Range of application

- Sealing of foundation pits
- Soil solidification/stabilization of foundation soil
- Filling of cavities/voids
- Post-construction damp proof course (dpc)
- Sewer repair

Suitable for

- PU injection foam resins
- PU combi injection resins
- PU injection resins
- PU casting foam resins (different mixing head)

Properties

- Mixing ratio 1 : 1
- Robust design, suitable for construction sites
- Adjustable pressure
- Different connection systems optionally available
- High dosing accuracy
- Compressed air-operated
- High delivery rate
- Easy to clean and maintain



WEBAC-Chemie GmbH
Fahrenberg 22
22885 Barsbüttel
Germany
Tel. +49 40 67057-0
Fax +49 40 6703227
info@webac.de

www.webac.de

▶ Technical Information

All the data indicated in this technical data sheet and any related information provided by our employees are of an advisory nature representing our current state of knowledge and in no way binding. As the exact chemical, technical and physical conditions of the actual application are beyond WEBAC's control, this information does not preclude examination of the products and/or procedures for the intended application and surface by the user. WEBAC is thus unable to guarantee results. The user is fully responsible for the observation of existing regulations and conditions when using the products.
© WEBAC-Chemie GmbH. Version 03/17

Injection Pumps

WEBAC® IP 2K-F2 CE

Design of pump

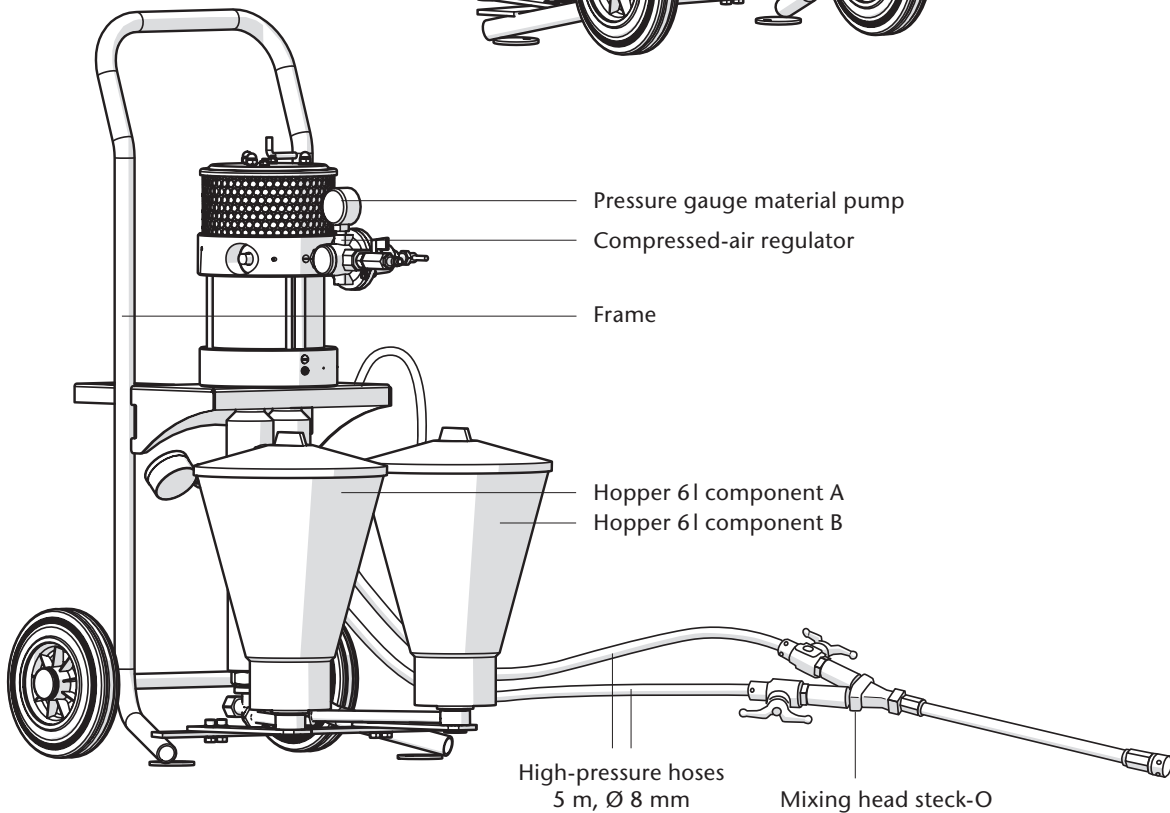
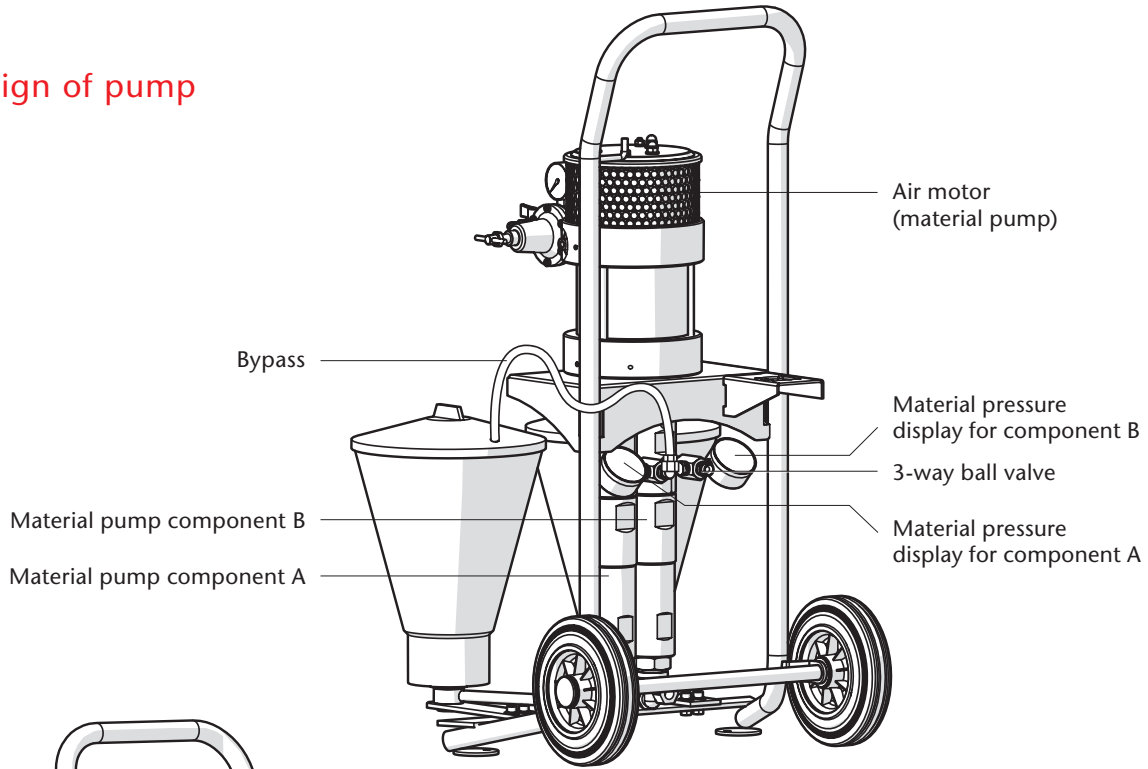

WEBAC-Chemie GmbH
 Fahrenberg 22
 22885 Barsbüttel
 Germany
 Tel. +49 40 67057-0
 Fax +49 40 6703227
 info@webac.de

www.webac.de

► Technical Information

All the data indicated in this technical data sheet and any related information provided by our employees are of an advisory nature representing our current state of knowledge and in no way binding. As the exact chemical, technical and physical conditions of the actual application are beyond WEBAC's control, this information does not preclude examination of the products and/or procedures for the intended application and surface by the user. WEBAC is thus unable to guarantee results. The user is fully responsible for the observation of existing regulations and conditions when using the products.
 © WEBAC-Chemie GmbH. Version 03/17

Injection Pumps

WEBAC® IP 2K-F2 CE

Technical data	Values
Pressure ratio	15 : 1
Max. flow rate at free flow	≈ 25 l/min
Delivery rate per double stroke	≈ 144 cm ³
Max. inlet pressure/ safety valve	8 bar
Max. allowed working pressure	120 bar
Air requirement	≈ 300 – 400 l/min
Max. material temperature	80 °C / 176 °F
Dimensions (LxWxH)	≈ 68x55x100 cm
Weight	≈ 54 kg

WEBAC-Chemie GmbH
 Fahrenberg 22
 22885 Barsbüttel
 Germany
 Tel. +49 40 67057-0
 Fax +49 40 6703227
 info@webac.de

www.webac.de

Operation

For the operation of the injection pump, see the pump manual.

Cleaning

- Clean the injection pump with **WEBAC® Cleaner A**
- Observe the technical data sheets of the cleaner used
- For detailed information refer to the operating manual of the injection pump

Storage

- Always store the injection pump in an upright position
- Fill the cleaned pump system with (water-free) hydraulic oil in case of long non-operating periods

► Technical Information

All the data indicated in this technical data sheet and any related information provided by our employees are of an advisory nature representing our current state of knowledge and in no way binding. As the exact chemical, technical and physical conditions of the actual application are beyond WEBAC's control, this information does not preclude examination of the products and/or procedures for the intended application and surface by the user. WEBAC is thus unable to guarantee results. The user is fully responsible for the observation of existing regulations and conditions when using the products.
 © WEBAC-Chemie GmbH. Version 03/17

Injection Pumps

WEBAC® IP 2K-F2

Overview: Range of application

	Sealing of Masonry	Gel Injection (Curtain Injection)	Stabilization of Structures	Crack Repair	Sealing of Joints	Monument Conservation	Sealing of Foundation Pits	Sewer Repair	Soil Solidification
1C pumps	WEBAC® IP EasyPro	✓	✓	✓	✓	✓		✓	✓
	WEBAC® IP 1K-F3	✓		✓	✓	✓		✓	✓
	WEBAC® HP 100	✓		✓	✓	✓			
	WEBAC® HP 250	✓		✓	✓	✓			
	WEBAC® HEP 1001	✓		✓	✓	✓			
2C pumps	WEBAC® IP 2K-F1	✓	✓		✓		✓	✓	✓
	WEBAC® IP 2K-F2	✓		✓		✓	✓	✓	✓
	WEBAC® HP 50 2K	✓		✓	✓	✓			



WEBAC-Chemie GmbH
 Fahrenberg 22
 22885 Barsbüttel
 Germany
 Tel. +49 40 67057-0
 Fax +49 40 6703227
 info@webac.de

www.webac.de

Occupational safety

The safety regulations of the industrial trade associations and the WEBAC Safety Data Sheets are to be observed at all times when working with this product. Safety data sheets according to Regulation (EC) No. 1907/2006 (REACH) must be accessible to all persons responsible for occupational safety, health protection and the handling of materials. For further information, please see the separate information sheet "Occupational Safety" in our product catalog or www.webac-grouts.com.

Waste disposal

In Germany, empty containers can be disposed of via "Interseroh Dienstleistungs GmbH" observing the respective terms and conditions. It is not possible to dispose of containers at production facilities or delivery warehouses. For more detailed information, please see the separate information sheet "Information on the disposal and return of WEBAC packaging" in our product catalog or www.webac-grouts.com and the safety data sheets.

► Technical Information

All the data indicated in this technical data sheet and any related information provided by our employees are of an advisory nature representing our current state of knowledge and in no way binding. As the exact chemical, technical and physical conditions of the actual application are beyond WEBAC's control, this information does not preclude examination of the products and/or procedures for the intended application and surface by the user. WEBAC is thus unable to guarantee results. The user is fully responsible for the observation of existing regulations and conditions when using the products.
 © WEBAC-Chemie GmbH. Version 03/17